

# BTS5590G, BTS5576G and BTS5566G

SPI Power Controller

Application Note

Short Circuit to VBB and Open Load Detection

Automotive Power



Never stop thinking

## 1 Abstract

*Note: The following information is given as a hint for the implementation of the device only and shall not be regarded as a description or warranty of a certain functionality, condition or quality of the device.*

This Application Note is intended to provide detailed application hints regarding the short circuit to  $V_{BB}$  detection of the BTS5590G, BTS5576G and BTS5566G SPI Power Controllers. Furthermore, an open load in off detection can be implemented with the use of an external resistor. General information about the SPI Power Controller can be found in the BTS5590G, BTS5576G and BTS5566G data sheets.

## 2 Introduction

The BTS5590G, BTS5576G and BTS5566G are five channel high-side power switches, which are especially designed to control standard exterior front and rear lighting in automotive applications.

Configuration and status diagnosis is done via SPI. Additionally, there is a current sense signal available for each channel that is routed via a multiplexer to one diagnostic pin.

This document will show how to use the internal function of the switch bypass monitor (SBM) to detect whether the output is connected via a low resistance to  $V_{BB}$  or not. For this short circuit to  $V_{BB}$  detection no external hardware is required. For the implementation of an open load in off detection an external resistor is required.

## 3 Functionality of Switch Bypass Monitor (SBM)

The switch bypass monitor (SBM) is a part of the device logic, which evaluates the  $V_{DS}$ -voltage of the DMOS. There is only one SBM comparator on the device for all five channels. Thus, there is an additional multiplexer implemented, which connects the outputs of the channels to the SBM comparator. This multiplexer is also programmed by the current sense multiplexer bits of the diagnosis control register. For further details please refer to the datasheet.

In case of a short circuit to  $V_{BB}$  and  $V_{DS} < V_{DS(SB)}$  the SBM-bit within the HWCR register indicates the short circuit to  $V_{BB}$ . This can be seen in the following two tables for off- and on-state:

**Table 1 SBM and Current Sense during off-state**

Operation mode	Current sense	SBM-bit
Normal operation	Z	1
Short Circuit to GND	Z	1
Over Temperature	Z	x
Short Circuit to $V_{BB}$	Z	0
Open Load	Z	x

**Table 2 SBM and Current Sense during on-state**

Operation mode	Current sense	SBM-bit
Normal operation	$I_L / k_{ILIS}$	0
Current Limitation	Z	x
Short Circuit to GND	Z	1
Over Temperature	Z	x
Short Circuit to $V_{BB}$	$< I_L / k_{ILIS}$	0
Open Load	Z	0

Z = high impedance, potential depends on leakage currents and external circuits, x = undefined

Functionality of Switch Bypass Monitor (SBM)

Note: During off-state the SBM-bit depends on the potential at the output pin. The potential of the output pin depends in open load case on leakage currents. As a result, the SBM bit can be set or reset during an open load in off-state.

### 3.1 Use of SBM for Short Circuit to $V_{BB}$ Detection

In case of a short circuit between the output-pin and the  $V_{BB}$ -pin a major part of the load current will flow through the short circuit. As a result, a lower current compared with the normal operation will flow through the DMOS of the BTS5590G, BTS5576G and BTS5566G, which can be recognized at the current sense signal.

In case of a current sense signal below the normal value, a software strategy is required to verify, whether an over temperature failure or a short circuit to  $V_{BB}$  leads to the low current sense signal.

The following flow chart shows a possible way to implement a software strategy:

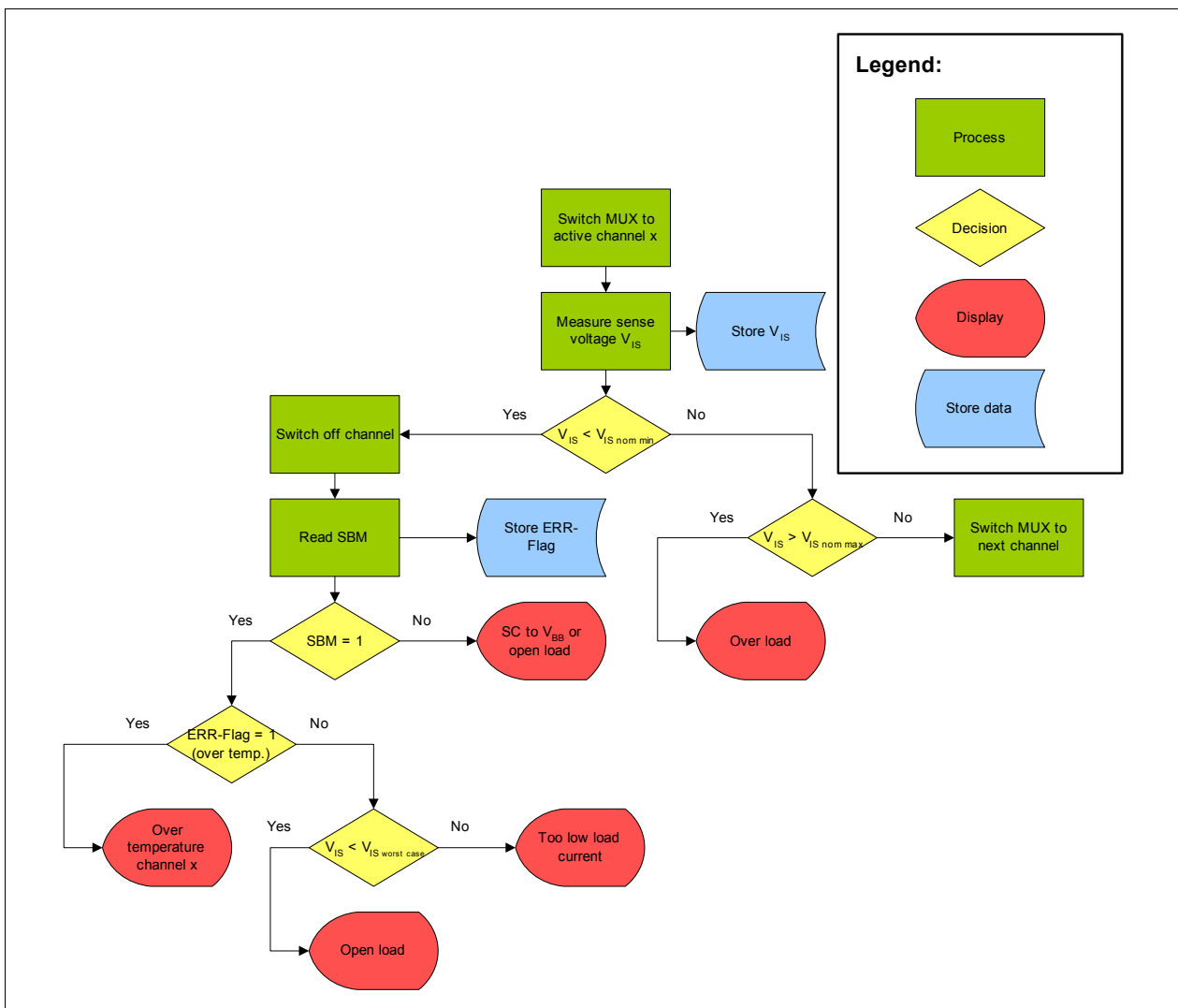

Figure 1 Flow Chart for the Verification, if a Short Circuit to  $V_{BB}$  or an Over Temperature Shutdown occurred

With this software routine it is possible to distinguish between short circuit to  $V_{BB}$  and over temperature. A complete differentiation between short circuit to  $V_{BB}$  and open load is not possible, because during open load the output potential depends on leakage currents. This can also cause a  $V_{DS}$  voltage below  $V_{DS(SB)}$ . Therefore, the open load case may behave like a short circuit to  $V_{BB}$ .

Functionality of Switch Bypass Monitor (SBM)

For the determination of  $V_{IS\ nom\ min}$  and  $V_{IS\ nom\ max}$  please refer to the following two equations.

$$V_{IS\ nom\ min} = \frac{I_{nom\ min}}{k_{ILIS\ max}} \cdot R_{IS\ min} \quad (1)$$

$$V_{IS\ nom\ max} = \frac{I_{nom\ max}}{k_{ILIS\ min}} \cdot R_{IS\ max} \quad (2)$$

For the determination of  $V_{IS\ worst\ case}$  please refer to the following calculation.

For example: The nominal load of channel 0 is a 21 W bulb. But it is also possible to put a 10 W or 5 W bulb into the socket of the 21 W load. Therefore, it might be interesting to recognize, if there is an open load or only a wrong bulb connected. The implementation of a  $V_{IS}$ -threshold with a value of 0.5 V for a sense resistor  $R_{IS} = 4.7\ k\Omega$  is recommended. So, if the  $V_{IS}$  voltage is below this threshold, then an open load failure is detected, otherwise a too low load current caused the failure.

The following calculation shows an example with typical values in bulb-mode, how the minimum sense voltage can be calculated. For devices with LED-mode higher accuracies can be achieved by switching into LED-mode.

Nominal current of a 10 W bulb:  $I_{nom\ 10\ W} = 0.74\ A$

Typical  $k_{ILIS}$  ratio for channel 0 in bulb-mode:  $k_{ILIS} = 3100$

Typical sense resistor:  $R_{IS} = 4.7\ k\Omega$

$$V_{IS} = \frac{I_{nom\ 10\ W}}{k_{ILIS}} \cdot R_{IS} = \frac{0.74\ A}{3100} \cdot 4.7\ k\Omega = 1.1\ V \quad (3)$$

For the worst case calculation the following formula should be used:

$$V_{IS\ worst\ case} = \frac{I_{nom\ 10\ W\ min}}{k_{ILIS\ max}} \cdot R_{IS\ min} \quad (4)$$

The implemented threshold should be below this value.

### 3.2 Use of SBM for Differentiation between Short Circuit to $V_{BB}$ and Open Load

If a short circuit to  $V_{BB}$  should be distinguished from an open load (e.g. broken bulb) an external output pull down resistor is required. The following figure shows the circuit with the additional output pull down resistor  $R_{OUT\ pd}$ :

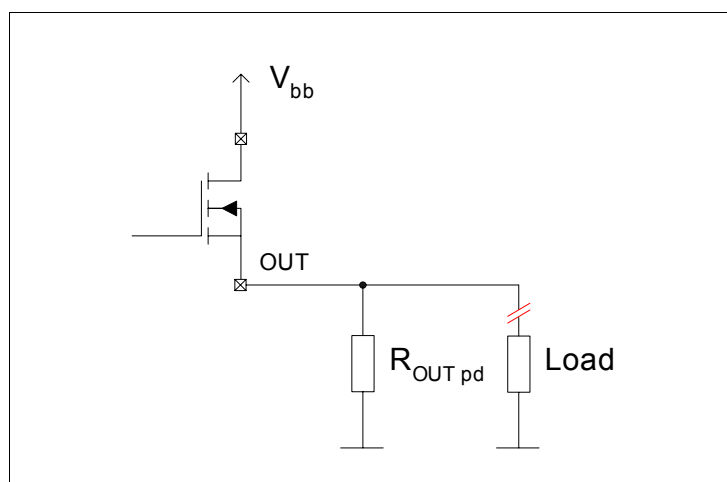

Figure 2 External Circuit for Open Load Detection in Off-state

Functionality of Switch Bypass Monitor (SBM)

With the following formula the output pull down resistor  $R_{OUT\ pd}$  can be calculated to ensure during open load condition that device and system leakage currents do not cause the SBM-bit to transition to a logic 0.

$$R_{OUT\ pd} < \frac{V_{BB} - V_{DS(SB)max}}{I_{L(OFF)max} + I_{Leakage\ system}} \quad (5)$$

Here an example:

$$R_{OUT\ pd} < \frac{9\ V - 2.5\ V}{40\ \mu A} = 162.5\ k\Omega \quad (6)$$

So, a pull down resistor of  $R_{OUT\ pd} = 100\ k\Omega$  could be used, if the leakage currents of the system are neglectable. The following figure shows the flow chart for the software strategy to distinguish between an open load or short circuit to  $V_{BB}$  failure:

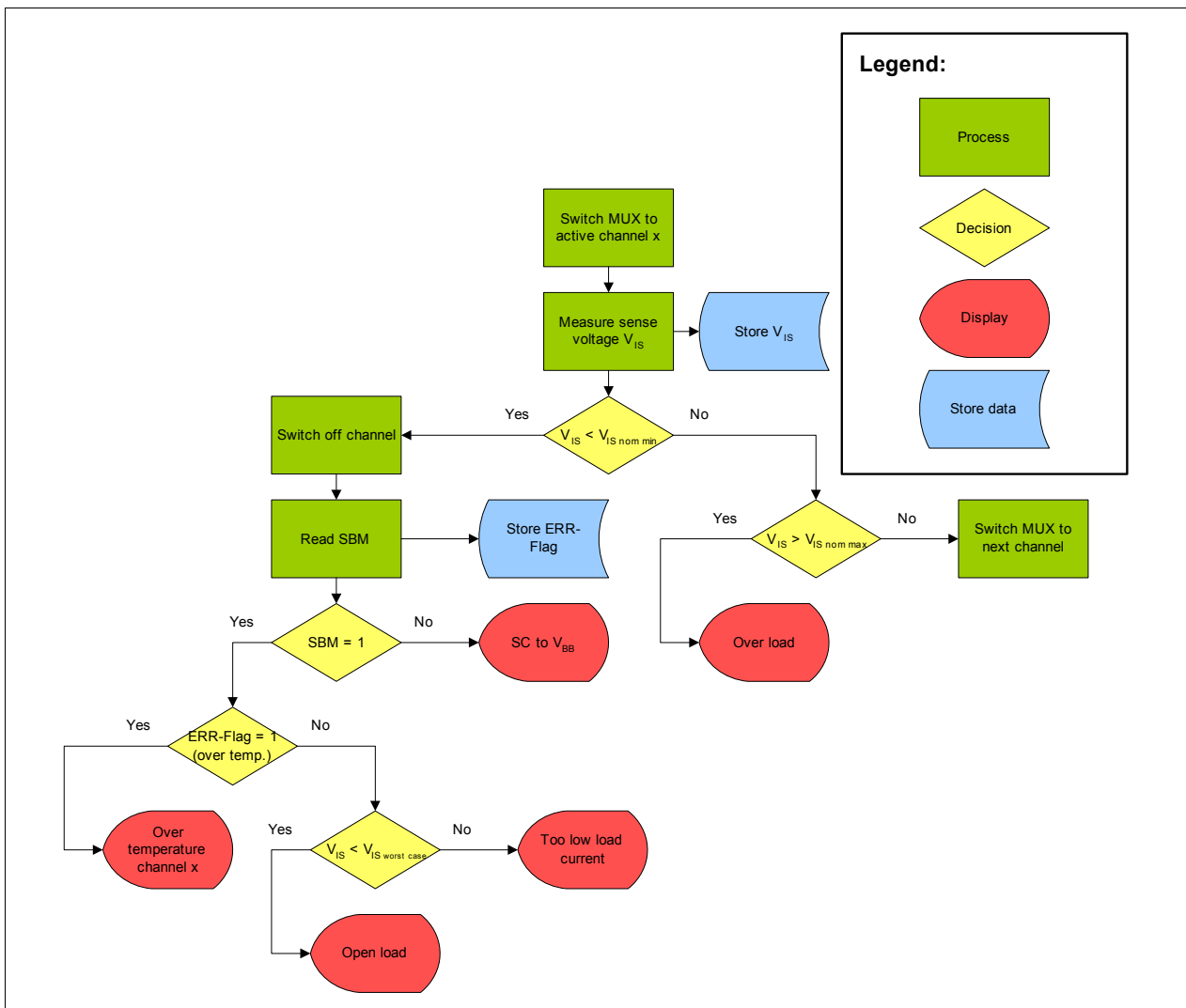

Figure 3 Flow Chart for the Verification, if a Short Circuit to  $V_{BB}$ , an Over Temperature Shutdown or an Open Load Failure occurred

In the figure above a the differentiation between open load and a too low load current can be done by the implementation of a  $V_{IS}$ -threshold voltage as described in the [Chapter 3.1](#).

## 4 Conclusion

By the use of the switch bypass monitor it is possible to distinguish between the in [Table 1](#) described operation modes. Therefore, a sophisticated software strategy is required.

### Summary:

- Without any external hardware it is possible to distinguish between short circuit to  $V_{BB}$ , over temperature and a too low load current. A complete differentiation between short circuit to  $V_{BB}$  and open load is not possible.
- By using an external output pull down resistor it is possible to distinguish between short circuit to  $V_{BB}$ , open load, over temperature and a too low load current.

## 5 Additional Information

Type	Ordering Code	Package
BTS5590G, BTS5576G and BTS5566G	on request	PG-DSO-36-34

More information regarding SPI Power Controllers can be found at <http://www.infineon.com/spoc>



**Edition 2008-07-14**

**Published by  
Infineon Technologies AG  
81726 Munich, Germany**

**© 2008 Infineon Technologies AG  
All Rights Reserved.**

### **Legal Disclaimer**

The information given in this document shall in no event be regarded as a guarantee of conditions or characteristics. With respect to any examples or hints given herein, any typical values stated herein and/or any information regarding the application of the device, Infineon Technologies hereby disclaims any and all warranties and liabilities of any kind, including without limitation, warranties of non-infringement of intellectual property rights of any third party.

### **Information**

For further information on technology, delivery terms and conditions and prices, please contact the nearest Infineon Technologies Office ([www.infineon.com](http://www.infineon.com)).

### **Warnings**

Due to technical requirements, components may contain dangerous substances. For information on the types in question, please contact the nearest Infineon Technologies Office.

Infineon Technologies components may be used in life-support devices or systems only with the express written approval of Infineon Technologies, if a failure of such components can reasonably be expected to cause the failure of that life-support device or system or to affect the safety or effectiveness of that device or system. Life support devices or systems are intended to be implanted in the human body or to support and/or maintain and sustain and/or protect human life. If they fail, it is reasonable to assume that the health of the user or other persons may be endangered.



# Mouser Electronics

Authorized Distributor

Click to View Pricing, Inventory, Delivery & Lifecycle Information:

[Infineon:](#)

[BTS5566G](#)